

## FEATURES

- ◆ Moving gantry provides large stationary work surface
- ◆ All axes provided with home reference switch and far end limit switch with  $\pm 0.01$  mm repeatability
- ◆ Y-axis is provided with aluminum dust cover and plastic lip seals to provide protection against contaminants
- ◆ X-axis bearings and drive screw are mounted beneath the work surface to protect them from dust and debris
- ◆ Touch and go joy stick, calibration touch pad
- ◆ SAC motion control software included (see page 171)
- ◆ All electronics and controls included
- ◆ 2 patented double linear rails and 2 patented double bearing blocks on each axis
- ◆ All models come with servo motors and line driver optical rotary encoder, 1000 line
- ◆ Anti-backlash screws on all axes
- ◆ Rapid speeds up to 800 inches per minute
- ◆ Cable carriers on all machines to route motor cables
- ◆ Heavy welded steel machine base, ground flat and stress relieved with powder-coated finish
- ◆ Available with optional vacuum table. Call factory for details



**Applications Include:** Inspection  
 Fluid Dispensing  
 Parts Transfer  
 Assembly  
 Automatic Welding

**NOTE:** Table shown with optional 19" Gantry clearance.



CATALOG NUMBER

For 59" x 50" (Model 160) Machine

For 59" x 96" (Model 210) Machine

HX43VBM50□50□05

HX43VBM48□96010

**Gantry Clearance**

- 0 6 3/8" ( 8.7" Z travel)
- 3 11" (12.7" Z travel)
- 5 19" (16.6" Z travel)\*

**Frame**

- 0 Closed
- 1 Open\*\*

**Gantry Clearance**

- 0 6 3/8" ( 8.7" Z travel)
- 3 11" (12.7" Z travel)
- 5 19" (16.6" Z travel)\*

For 59" x 120" (Model 230) Machine

For 59" x 144" (Model 260) Machine

HX43VBM59□12010

HX43VBM59□14010

**Gantry Clearance**

- 0 6 3/8" ( 8.7" Z travel)
- 3 11" (12.7" Z travel)
- 5 19" (16.6" Z travel)\*

**Gantry Clearance**

- 0 6 3/8" ( 8.7" Z travel)
- 3 11" (12.7" Z travel)
- 5 19" (16.6" Z travel)\*

Built to order. Call for delivery.

\* For light loads only.

\*\* Open-frame machines have XY travel of 50" x 50".

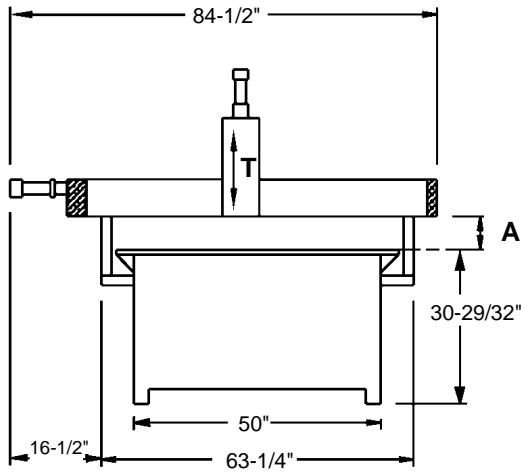

(A: 6.5" )  
 11"  
 19.25" )\*

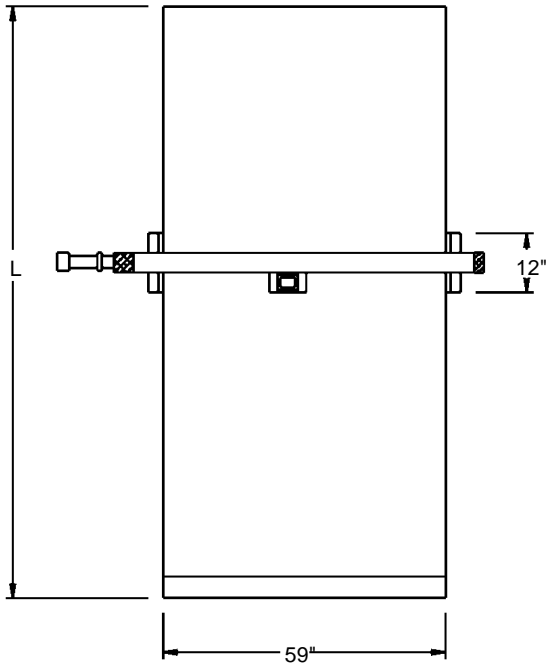
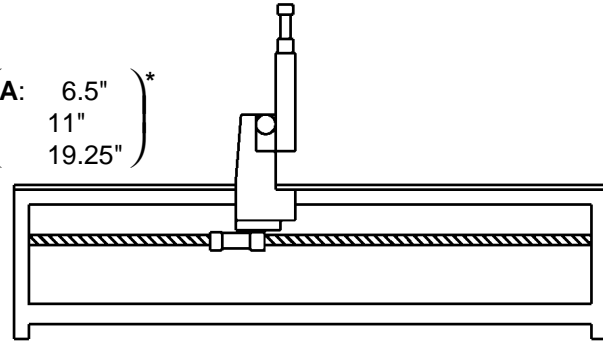

L: 83" for the 59" x 50" machine  
 121" for the 59" x 96" machine  
 148" for the 59" x 120" machine  
 168" for the 59" x 144" machine

\* "A" dimension indicates Gantry clearance

SPECIFICATIONS	HX43VBM50□50005	HX43VBM48□96010	HX43VBM59□12010	HX43VBM59□14010
Travel	59" x 50"	59" x 96"	59" x 120"	59" x 144"
Work Surface Area	59" x 80"	59" x 120"	59" x 144"	59" x 168"
Repeatability	±.001"	±.001"	±.001"	±.001"
Positioning Accuracy	±.004 / 12" per axis	±.004 / 12" per axis	±.004 / 12" per axis	±.004 / 12" per axis
Maximum Z-Axis Load	75 lbs	75 lbs	75 lbs	75 lbs
Rapid Speed (Max.)	800 in / min	800 in / min	800 in / min	800 in / min
Cutting Speed (Max.)	400 in / min	400 in / min	400 in / min	400 in / min
Resolution	.0002"	.0002"	.0002"	.0002"
Table Flatness	.008" / 12"	.008" / 12"	.008" / 12"	.008" / 12"

2 MACHINES & SLIDES